



# hopeSun Series String Inverter (8KTL~33KTL) User Manual

Version: V1.0

Shenzhen Hopewind Electric Co., Ltd.

# hopeSun Series String Inverter

(8KTL~33KTL)

## **User Manual**

Version: V1.0

---

Thank you for purchasing products developed and manufactured by Shenzhen Hopewind Technology Co., Ltd. (hereinafter referred to as "Hopewind"). Hope our products and this manual can meet your demands. Any suggestion for improvement shall be appreciated.

Shenzhen Hopewind Technology Co., Ltd. reserves the copyright of this manual, and it shall be subject to change without any further notice.

# About this manual

## ➤ For Readers



This manual is helpful for technicians who install, debug, operate and maintain string inverters of Hopewind. Please read this manual carefully before operates the product.

Readers are required to know the basic knowledge about electric components, wiring, signs and mechanical drawings.

## ➤ Outlines

Chapter	Contents
1 Safety Precautions	This chapter describes the safety precautions when transporting, storing, installing, running and maintaining the Inverter.
2 Product Description	This chapter describes the basic principles, naming rules, product configuration and data.
3 System Installation	This chapter describes the unpacking inspection, installation tools, installation environment, reserved space, fixing method, cable connection.
4 Commissioning Guide	This chapter describes the inspection before startup, Commissioning and startup of string inverter.
5 Maintenance and Troubleshooting	This chapter describes the daily maintenance methods, maintenance intervals and troubleshooting of the product.
6 Inverter handling Guide	This chapter describes the basic requirements and precautions when disassembling, replacing, and scrapping the inverter.

## ➤ Warning Signs in This Manual

 <b>DANGER</b>	It shows that there is a significant potential danger. If the operation is not performed according to requirements, serious injury or damage may be caused to people or equipment.
 <b>WARNING</b>	It shows that there is a general potential danger. If the operation is not performed according to requirements, general injury or damage may be caused to people or equipment.
 <b>CAUTION</b>	It shows that there is a general potential danger. If the operation is not performed according to requirements, general injury or damage may be caused to equipment.

## ➤ Terms and Abbreviations

Terms/Abbreviations	Description
MPPT	Maximum Power Point Tracking
Photovoltaic string	Multiple solar cell arrays in parallel or series.
EEPROM	Electrically Erasable Programmable Read-Only Memory
hopelnsight	A monitoring and debugging software for inverter.

## ➤ Version Description

Version	Release Date	Description
V1.0	2021-8-5	The first version

# Content

<b>About this manual</b> .....	<b>5</b>
<b>1 Safety Precautions</b> .....	<b>1</b>
1.1 Transportation.....	1
1.2 Storage.....	1
1.3 Installation.....	2
1.4 Operation.....	2
1.5 Maintenance.....	3
<b>2 Product Description</b> .....	<b>5</b>
2.1 Product Description.....	5
2.1.1 Schematic Diagram.....	5
2.1.2 Operation Mode.....	6
2.2 System Configuration and Application.....	6
2.2.1 Application Description.....	6
2.2.2 Supported Grid Form.....	7
2.3 Naming Rules.....	7
2.4 Nameplate label.....	8
2.5 Machine Configuration.....	9
2.6 Signs and labels.....	11
2.7 Warning Labels in Inverter.....	11
2.8 Technical Data.....	12
2.9 Mechanical Parameters.....	14
2.10 Ambient Requirements.....	14
<b>3 System installation</b> .....	<b>17</b>
3.1 Unpack and inspection.....	17
3.2 Preparation of installation tools.....	17
3.3 Installation environment requirements.....	17
3.4 Requirements for reserved space.....	18
3.5 Fixing method.....	19
3.6 Electrical connection.....	20
3.6.1 Cable requirements.....	20
3.6.2 Recommended cable specifications.....	20
3.6.3 Torque requirements.....	21
3.6.4 Preparation before operation.....	21
3.6.5 Connect the ground wire.....	22
3.6.6 Connect the AC output cable.....	22
3.6.7 Connect the communication cable.....	24
3.6.8 Connect DC input cables.....	25
<b>4 Commissioning Guide</b> .....	<b>27</b>
4.1 Check before starting.....	27
4.2 Power on the system.....	28
4.3 Power off the system.....	28
<b>5 Maintenance and troubleshooting</b> .....	<b>29</b>
5.1 Maintenance items and cycle.....	29
5.2 Troubleshooting.....	30
<b>6 Inverter handling instructions</b> .....	<b>35</b>
6.1 Disassembly of the inverter.....	35
6.2 Replace the inverter.....	35
6.3 Package the inverter.....	35
6.4 Scrapped the inverter.....	35

# 1 Safety Precautions

This chapter describes the safety precautions to be observed during the installation, operation and maintenance of inverter. Please carefully read the safety precautions before the installation, maintenance and other operations of inverter. All personals must strictly observe safety precautions during the operation. Personal injury or damage to inverter and associate devices may occur if the safety precautions are ignored.

When operating the inverter, please pay particular attention to the following items:



1. Only qualified professionals can install, operate and maintain the inverter.
2. Please avoid toppling and knocking the inverter cabinet during moving the inverter.
3. Prevent liquid, debris or chippings from getting inside the inverter; a conductive fluid and debris may cause an internal short circuit of inverter and result in equipment damage.
4. Before completing installation and maintenance, the inverter must be isolated from power grid and other electrified devices.
5. Please make sure that relevant protective measures have been taken to avoid electric shock, fire or other accidents.



**Don't place explosive and inflammable substances around the inverter!**

## 1.1 Transportation



1. Please keep the inverter well packed and upward, avoid strong shock or collision during the transportation.
2. Please transport the inverter with package and operate in accordance with the signs and labels during the transportation. Please refer to "2.6 Signs and labels" for detailed information.
3. Please ensure the transportation environment can meet the requirements. Please refer to "2.10 Ambient Requirements" for detailed information.

## 1.2 Storage



The storage environment of inverter should meet the corresponding requirements. Please refer to "2.10 Ambient Requirements" for detailed information.

### **About long-term storage:**

Before or after the installation, it's regarded as long-term storage if the inverter has been in the no power supply status for over three weeks. Please pay attention to the following issues about long-term storage:

- Put the desiccant into several equipment cabinets and pack the inverter with packaging materials;
- Attention must be paid to ventilation and moisture prevention where equipment is stored and any water is strictly prohibited;
- Necessary measures must be taken to deal with adverse environments, such as abrupt cooling and heating, collision and dust storm to prevent damages to the inverter.
- Regular inspection at least once a week, inspect whether the package is intact and prevent it from damages caused by insects and rats. Please replace the damaged package immediately.
- The inverter shall be unpacked, inspected, repacked, and replace the new desiccant if it is stored for over

half a year.

- Don't store the inverter without package.

### 1.3 Installation



1. The DC switch and breaker of the inverter must be cut off and the inverter shell must be reliably grounded before any operation is conducted inside the inverter.
2. The inverter must be grounded canonically and the dimension of grounding conductor must conform to the requirements of security specifications to ensure the personal safety.
3. Don't place explosive and inflammable substances around the inverter.



1. The installation environment of the inverter must have good ventilation and heat dissipation, the inverter can't expose to the sunlight directly.
2. It's advised to fix the inverter by four personals to avoid mechanical injury. Please take safety measures to prevent injury during installation.
3. Liquid, dust or debris must be prevented from entering the inverter during installation and maintenance as conducting liquid and debris may cause short circuit inside the inverter, thus damaging the equipment.
4. Please ensure the installing torque of power cable is proper during the wiring of external cables and inverter, excessive torque will damage the screw, and too small torque will increase the contact resistance and result in overheating.
5. The terminal of the power cable connected with the inverter must comply with national standard as substandard terminal or disqualified construction may lead to overheating of the power cable and outbreak of fire in severe cases.
6. Installation place must meet the operation environment requirements. Please refer to "2.10 Ambient Requirements" for detailed information.

### 1.4 Operation



1. During the operation of inverter, the cabinet door of inverter needs to be locked to avoid electric shock and other personnel injuries, which can also prevent salinity, water, dust or other conducting materials in the air from entering into inverter.
2. Please keep the surrounding environment of operating inverter non-corrosive.
3. Don't place explosive and inflammable substances within two meters from the inverter.
4. Don't touch the internal board, components, cables and terminal blocks of inverter during the powering on.
5. When there are faults or abnormal smell or sound, turn off the DC switch and open the breaker of AC side immediately.



1. Power on the inverter only after completing the installation and properly connecting the cables.
2. Do not conduct any insulation resistance test or high-voltage resistance test for inverter, because wrong test may cause damages to inverter.
3. Cut off wiring between inverter and external equipment when conducting insulation and voltage resistance test for external equipment.

## 1.5 Maintenance

c

1. Please cut off the AC side breaker first, then cut off the DC switch, and wait for at least 5 minutes before performing maintenance.
2. Please prevent irrelevant persons from entering maintenance scene during the maintenance.
3. Please maintain the inverter under the condition of understanding this manual and being equipped with proper tools and test devices.
4. Please wear insulating gloves and safety shoes for your safety.



Regular check and maintenance must be performed, please refer to "5 Maintenance and troubleshooting" for details.

--Chapter End--

# 2 Product Description

## 2.1 Product Description

hopeSun series three-phase string on-grid inverter is independent developed by Hopewind. it's main function is converting DC current generated by PV arrays into AC current and feeding it into the grid.

hopeSun 8KTL/10KTL/12KTL are 2-input string inverters. hopeSun 15KTL/17KTL are 3-input string inverters. hopeSun 20KTL/22KTL/25KTL are 4-input string inverters. hopeSun 30KTL/33KTL are 6-input string inverters. These products only suit for 400VAC low-voltage grid-connected scenarios, such as village-level photovoltaic power stations below 400KW or industrial and commercial rooftop photovoltaic power stations.

### 2.1.1 Schematic Diagram

hopeSun 8KTL/10KTL/12KTL are connected to the inverter through 2 PV string inputs. hopeSun 15KTL/17KTL are connected to the inverter through 3 PV string inputs. hopeSun 20KTL/22KTL/25KTL are connected through 4 PV string inputs In the inverter. hopeSun 30KTL/33KTL are connected to the inverter through 6 PV string inputs. There are 2 MPPT circuits inside the inverter for MPPT tracking of the strings, and then the inverter circuit realizes DC conversion to three-phase Alternating current as he schematic diagram below.

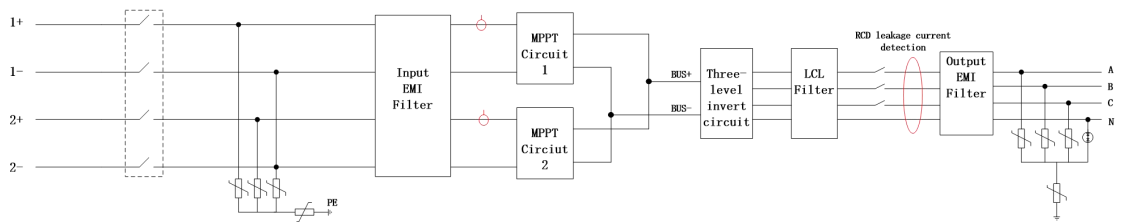

Figure 2-1 Two-input string inverter system schematic diagram

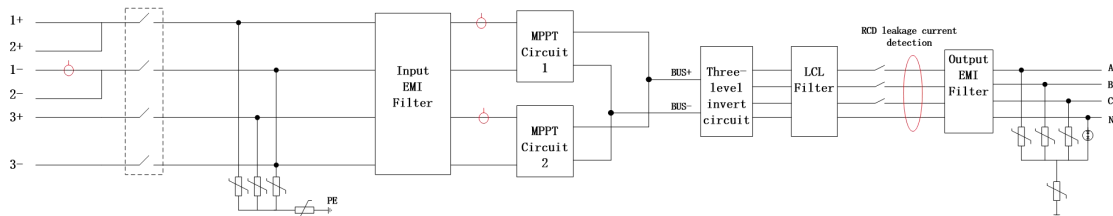

Figure 2-2 Three-input string inverter system schematic diagram

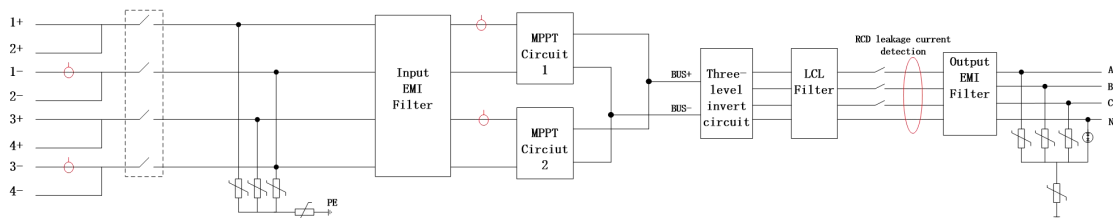

Figure 2-3 Four-input string inverter system schematic diagram

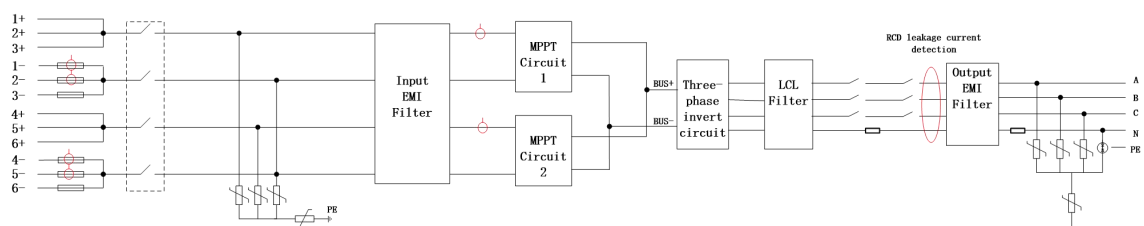

Figure 2-4 Six-input string inverter system schematic diagram



## 2.1.2 Operation Mode

hopeSunHV string inverter includes three operation modes: standby mode, operation mode and shutdown mode. The three mode switching conditions are shown in Figure 2-5.

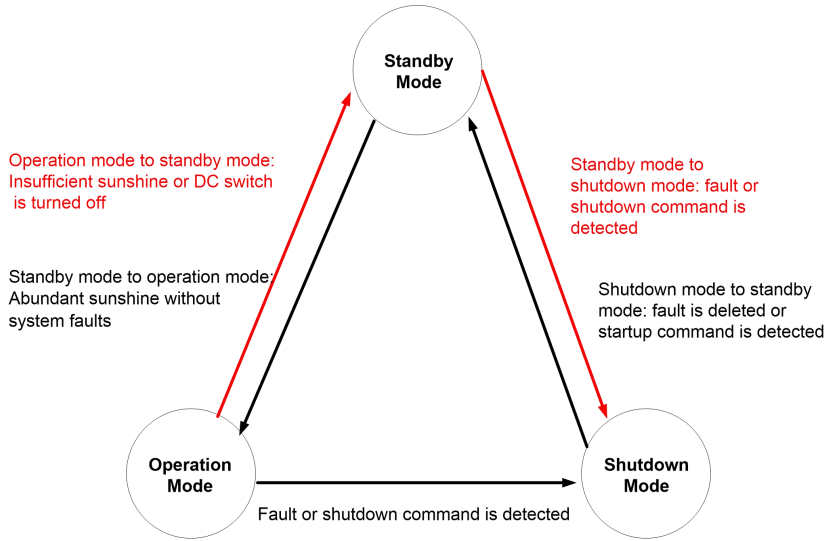

Figure 2-5 hopeSun string inverter operation mode

Operation Mode	Description
Standby	1) Standby mode mainly refers to the external environment doesn't meet the operation condition, such as insufficient sunshine or DC switch is turned off. Under this mode, the inverter continuously performs self-checking and enters operation mode once the operation conditions are satisfied. 2) Under standby mode, the inverter will enter shutdown mode after detecting the shutdown command or faults.
Operation	1) Under the operation mode, the inverter converts DC current of photovoltaic arrays into AC current and feeds it to the grid. The inverter performs MPPT arithmetic and outputs the maximum power of photovoltaic arrays. 2) The inverter will enter shutdown mode after detecting the faults or shutdown command. 3) The inverter will enter standby mode after detecting the input power of photovoltaic arrays is lower than the on-grid power generation condition.
Shutdown	1) If the inverter detects a fault occurrence or shutdown command during standby or operation mode, it enters shutdown mode. 2) In the shutdown mode, if the inverter detects that the fault has been cleared or the power-on command, it enters standby mode.

## 2.2 System Configuration and Application

### 2.2.1 Application Description

Figure 2-6 shows the application diagram of the string inverter network, Figure 2-7 shows the design scheme of the distributed PV power plant.

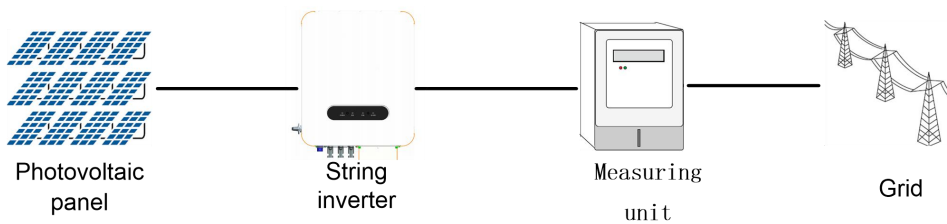

Figure 2-6 Application diagram of the string inverter network

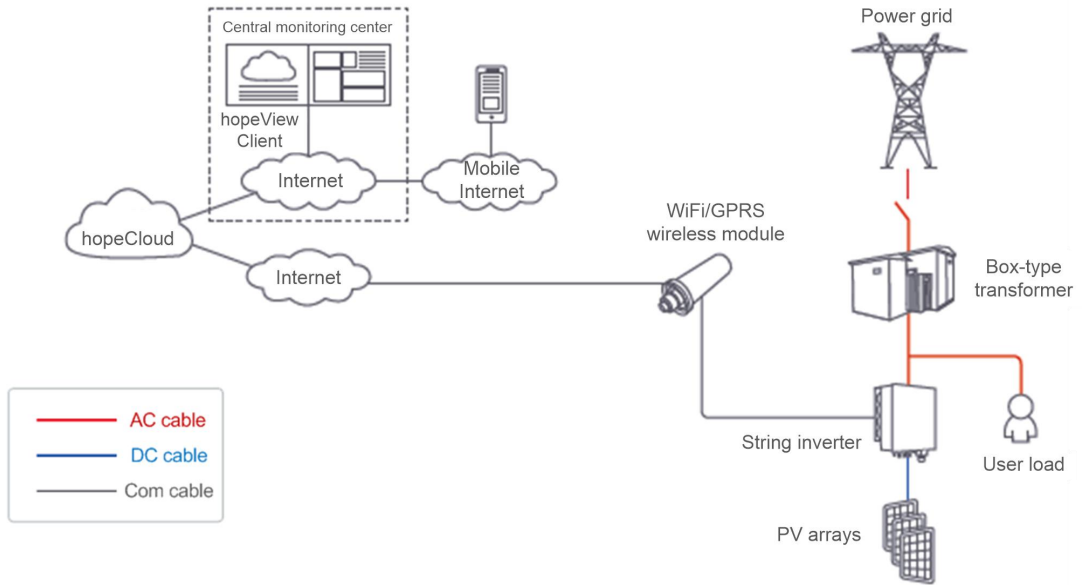

Figure 2-7 Design scheme of the I distributed PV power plant

### 2.2.2 Supported Grid Form

hopeSun 8KTL~hopeSun 33KTL support the TN-S, TN-C, TN-C-S, TT IT systems in Figure 2-8.

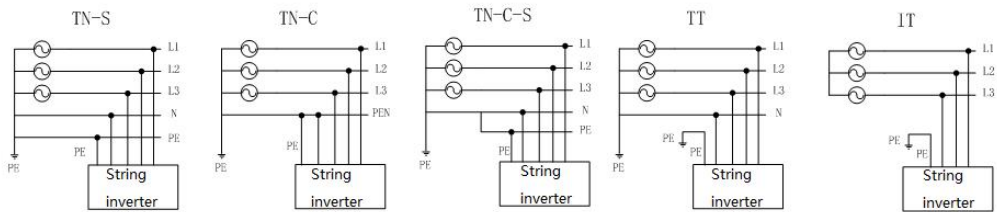

Figure 2-8 Schematic diagram of IT system

### 2.3 Naming Rules

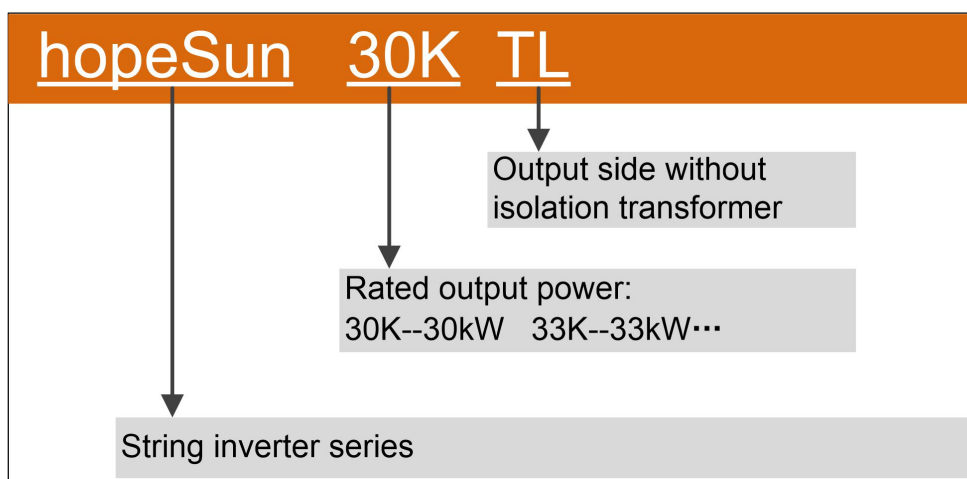

Figure 2-9 Naming rules

## 2.4 Nameplate label



光伏并网逆变器  
PV Grid-interactive Inverter

型号 Model: hopeSun 30KTL

产品序列号 Serial No. : 贴序列号标签

制造日期 Manufacture Date : 制造日期标签

最大输入电压 Max. Input Voltage : 1100Vd.c.

MPP电压范围 MPP Voltage Range : 200-1000Vd.c.

最大输入电流 Max. Input Current : 40A/40A

最大短路电流 Isc PV : 60A/60A

直流侧 DC

输出电压 Nominal Output Voltage : 400Va.c./230Va.c.;3P+N+PE

输出频率 Nominal Output Frequency : 50Hz/60Hz

额定输出功率 Rated Output Power : 30kW

最大输出功率 Max. Output Power : 33kW

最大输出电流 Max. Output Current : 47.8A

功率因数 Power Factor : 0.8 (lagging)-0.8 (leading)

交流侧 AC

工作环境温度 Operating Ambient Temperature : -40 to +60°C

防护等级 Ingress Protection : IP65

保护等级 Protection Class : I

VDE0126-1-1



深圳市禾望科技有限公司  
Shenzhen Hopewind Technology Co., Ltd

中国制造  
MADE IN CHINA

(Note: The data is for reference only; please refer to the physical or technical agreement of the corresponding product for actual parameters)

## 2.5 Machine Configuration

This section describes the internal components, back device, and bottom interface of the string inverter. Bottom structure may differ from other models, the 30KTL is taken as an example here.

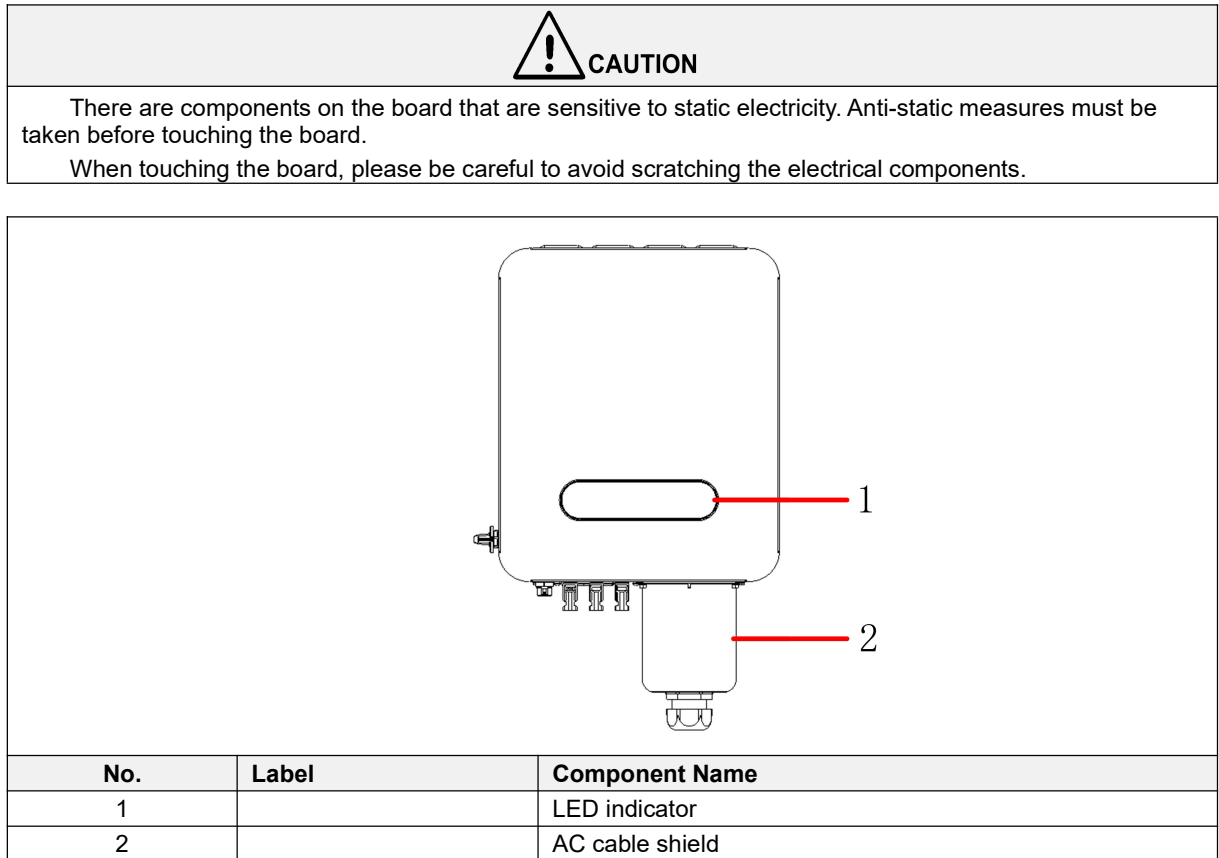





Figure 2-10 Front view of the inverter

The LED indicators from left to right are described as follows:

Table 2-1 LED Indicator Description

Indicator light	Meaning	Status	Meaning
	PV and grid connection	Blue indicator lights on	DC voltage is more than 200V and grid is connected normally.
		Blue indicator flashes	DC voltage is more than 200V (grid is not connected).
		Blue indicator lights off	At least 1 PV array is normally connected.
	On-grid operation	Blue indicator lights on	The inverter is in the on-grid status.
		Blue indicator lights off	The inverter is not connected to the grid.
	Communication indication	Blue indicator flashes	Normal communication.
		Blue indicator lights off	Abnormal communication.
	Alarm indication	Red indicator flashes slowly	PID is operating.
		Red indicator flashes	Abnormal alarm: regular alarm.
		Red indicator	Critical alarm: faults.

# User Manual of String Inverter

		lights on	
Remarks:			
<b>Slow flash</b> is defined as: 1 second lights up, 2 seconds lights off.			
<b>Flash</b> is defined as: 0.5 seconds lights up, 0.5 seconds lights off.			

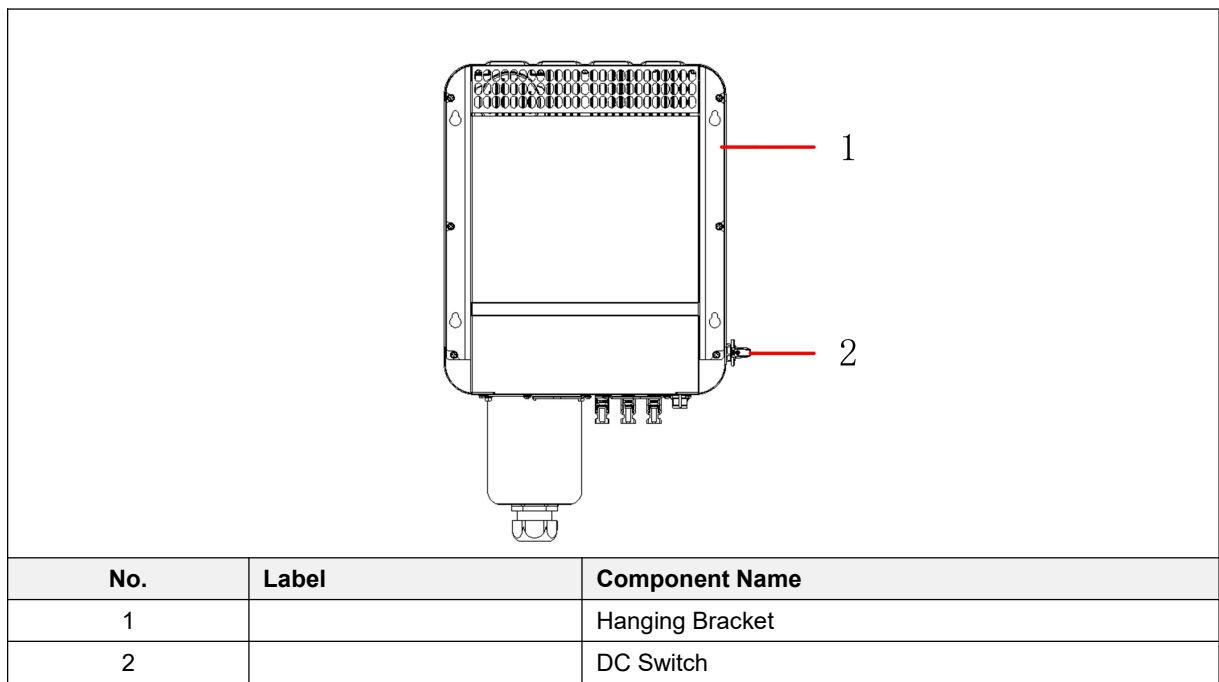

Figure 2-11 Back view of the inverter

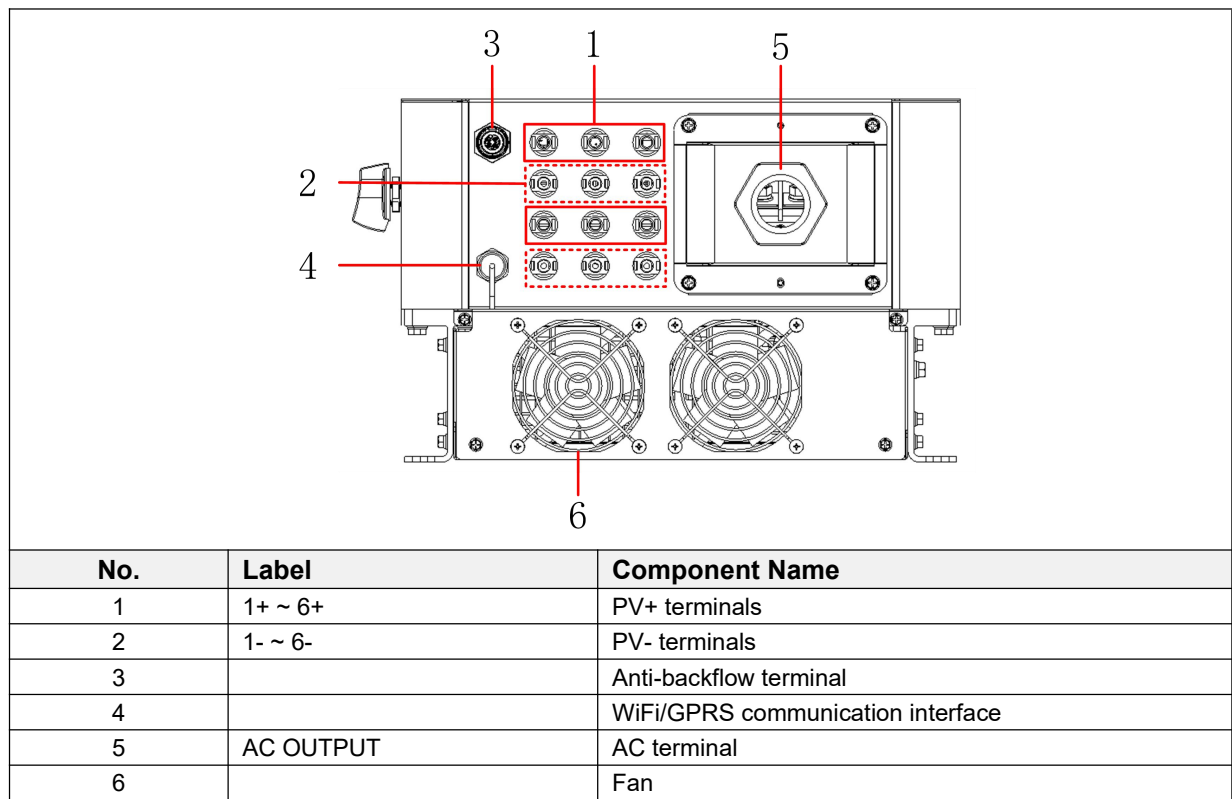
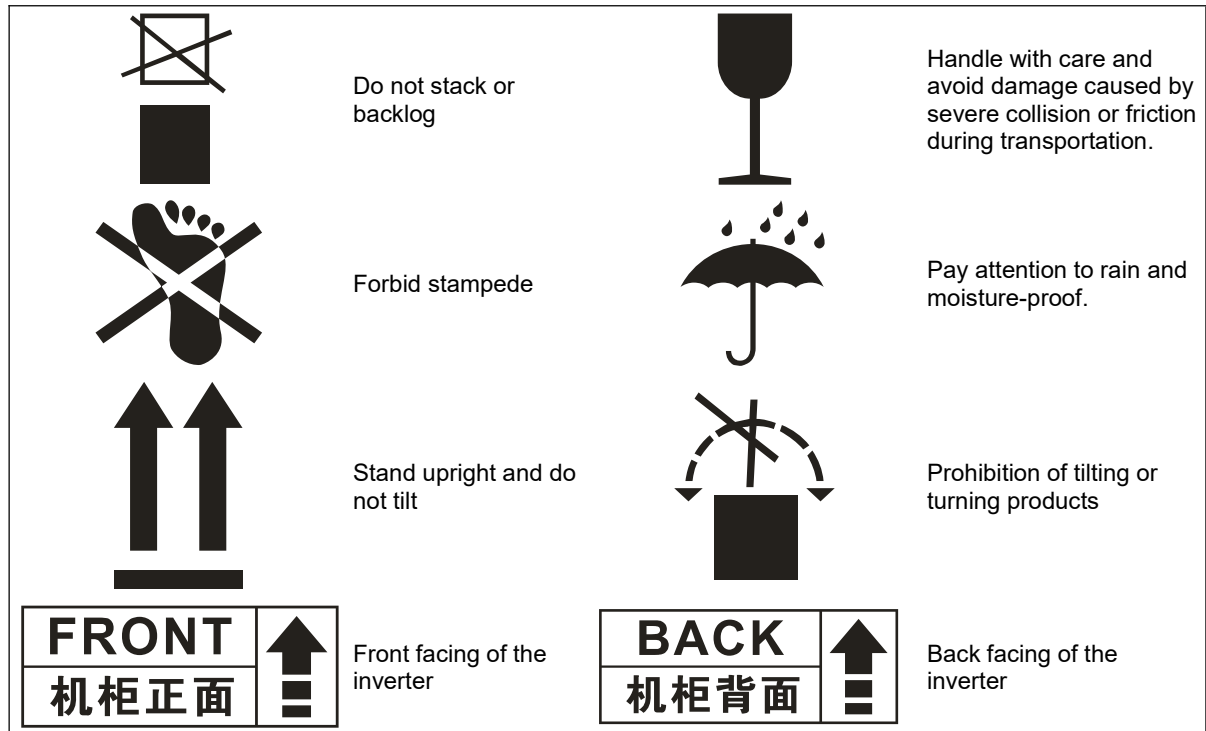

Figure 2-12 Bottom view of the inverter

Note: HopeSun 8KTL/10KTL/12KTL has only 2 PV inputs at the bottom, hopeSun 15KTL/17KTL has 3 inputs, hopeSun 20KTL/22KTL/25KTL has 4 inputs, and hopeSun 30KTL/33KTL has 6 inputs. HopeSun models of 17KTL and below have no cooling fan at the bottom.

## 2.6 Signs and labels

On the outer packaging of the product, there are some labels to guide the user to transport and store the product. The meanings indicated by the labels are as follows:



## 2.7 Warning Labels in Inverter

In order to ensure the safety of the person and property when using the product and to avoid accidents, the following warning labels may be provided inside and outside the body of the string inverter to remind the user of the safety precautions during operation.

	<b>PE:</b> Here is the protective grounding terminal, requires reliable grounding to ensure the safety of operators and equipment.
	<b>Warning:</b> This component may present a hazard other than high voltage, which the user should pay attention to.
	<b>High voltage hazard:</b> This component may present a high voltage hazard and the user must pay special attention.
	<b>Hot surface:</b> Pay attention to the hot surface to prevent burns.
	<b>Refer to the user manual:</b> Please refer to the corresponding instructions in the user manual before operation.
	<b>Discharge identification:</b> This equipment has an energy storage device. Before maintenance, it is necessary to wait for the energy storage device to discharge to prevent electric shock. The waiting time is not less than the indicated discharge time.

## 2.8 Technical Data

Model		hopeSun 8KTL	hopeSun 10KTL	hopeSun 12KTL	hopeSun 15KTL	hopeSun 17KTL
<b>DC parameters</b>	Maximum DC voltage	1100V				
	Starting Voltage	200V				
	MPPT Voltage Range	200V~1000V				
	MPPT Range Full Load	370V~850V			450V~850V	
	Max. Input Current of Each MPPT	20A / 20A			26A / 20A	
	Max. short-circuit current	30A / 30A			39A / 30A	
	Number of DC Inputs	1 / 1			2 / 1	
	MPPT Number	2				
<b>AC parameters</b>	Rated Output Power	8kW	10kW	12kW	15kW	17kW
	Max. Active Power (cos $\theta$ =1)	8.8kW	11kW	13.2kW	16.5kW	18.7kW
	Rated Output Voltage	400V (Three Phase) (380V optional)				
	Operating Voltage Range	300V~480V				
	Rated Output Current	11.6A	14.5A	17.4A	21.7A	24.6A
	Max. Output Current	12.7A	16.0A	19.1A	23.9A	27.0A
	Rated Grid Frequency	50Hz / 60Hz				
	Power Factor	0.8 (Leading) ~ 0.8 (Lagging)				
	THD	<3%				
<b>System parameters</b>	Max. Efficiency	98.60%			98.61%	98.62%
	European Efficiency	98.30%				
	AC/DC SPD	Yes				
	Insulation Impedance Detection	Yes				
	Residual Leakage Current Detection	Yes				
	PV String Fault Detection	Yes				
	Output Overcurrent Protection	Yes				
	Protection Degree	IP65				
	Operating Temperature Range	-25 $^{\circ}$ C ~ +60 $^{\circ}$ C				
	Cooling System	Natural Cooling			Smart Air Cooling	
	Standby Power Consumption	<1W				
	Topology Structure	Transformerless				
	Operating Altitude	4000m (Derating above 3000m)				
	Display	LED Indicator + APP				
	Communication	WiFi / GPRS / 4G				
	DC & AC Terminator	DC:MC4 AC:OT/ DT				
Certification	EN50549 / IEC61683 / IEC62109 / IEC61000 / IEC62116 / IEC61727 / CQC / CGC					
Optional	WiFi&GPRS Module / Anti-PID Module / Anti-Reversed Module					
<b>Mechanics Parameters</b>	Dimensions (H*W*D)	380*400*247mm				
	Weight	$\leq$ 22kg				

Model		hopeSun 20KTL	hopeSun 22KTL	hopeSun 25KTL	hopeSun 30KTL	hopeSun 33KTL
<b>DC parameters</b>	Maximum DC voltage	1100V				
	Starting Voltage	200V				
	MPPT Voltage Range	200V~1000V				
	MPPT Range Full Load	425V~850V				
	Max. Input Current of Each MPPT	30A / 30A		40A / 40A		
	Max. short-circuit current	45A / 45A		60A / 60A		
	Number of DC Inputs	2 / 2			3 / 3	
	MPPT Number	2				
<b>AC parameters</b>	Rated Output Power	20kW	22kW	25kW	30kW	33kW
	Max. Active Power (cos $\theta$ =1)	22kW	24.2kW	27.5kW	33kW	36.3kW
	Rated Output Voltage	400V (Three Phase) (380V optional)				
	Operating Voltage Range	300V~520V				
	Rated Output Current	28.9A	31.8A	36.1A	43.5A	47.6A
	Max. Output Current	31.8A	35.0A	39.7A	47.6A	52.4A
	Rated Grid Frequency	50Hz / 60Hz				
	Power Factor	0.8 (Leading) ~ 0.8 (Lagging)				
	THD	<3%				
<b>System parameters</b>	Max. Efficiency	98.63%	98.65%	98.94%	99.00%	98.80%
	European efficiency	98.30%				
	AC/DC SPD	Yes				
	Insulation Impedance Detection	Yes				
	Residual Leakage Current Detection	Yes				
	PV String Fault Detection	Yes				
	Output Overcurrent Protection	Yes				
	Protection Degree	IP65				
	Operating Temperature Range	-25 $^{\circ}$ C ~ +60 $^{\circ}$ C				
	Cooling System	Smart Air Cooling				
	Standby Power Consumption	<1W				
	Topology Structure	Transformerless				
	Operating Altitude	4000m (Derating above 3000m)				
	Display	LED Indicator + APP				
	Communication	WiFi / GPRS / 4G				
	DC & AC Terminator	DC:MC4 AC:OT/ DT				
Certification	EN50549 / IEC61683 / IEC62109 / IEC61000 / IEC62116 / IEC61727 / CQC / CGC					
Opcional	WiFi&GPRS Module / Anti-PID Module / Anti-Reversed Module					
<b>Mechanics Parameters</b>	Dimensions (H*W*D)	380*450*247mm				
	Weight	$\leq$ 25kg		$\leq$ 30kg	$\leq$ 35kg	



## 2.9 Mechanical Parameters

➤ Size and weight

Model	W*H*D (mm)	Net weight (kg)
hopeSun 8KTL	380*450*245	≤22
hopeSun 10KTL		
hopeSun 12KTL		
hopeSun 15KTL		
hopeSun 17KTL		
hopeSun 20KTL		≤25
hopeSun 22KTL		≤30
hopeSun 25KTL		
hopeSun 30KTL		≤35
hopeSun 33KTL		

Note: size does not contain hangers, handles, pads, and so on. Dimensional error: ± 10mm.

➤ Inverter structure size

Note: The model shown in the picture below is 30KTL. The inverter sizes of other models are similar, only the sizes of AC protection shell may be different.

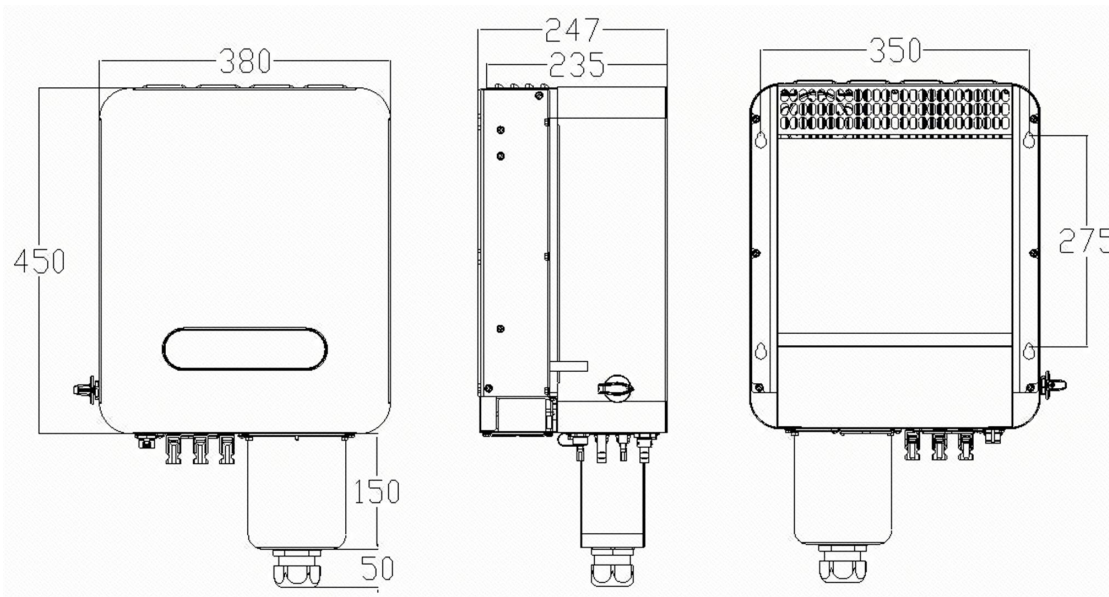

Figure 2-13 hopeSun series inverter and hanging board size (left, front, back, unit: mm)

## 2.10 Ambient Requirements

Transportation environment	Requirements
Type of shipping	Waterways, railways, highways, aviation, etc.
Ambient temperature	-25℃~+70℃
Relative humidity	≤95% when the temperature is +40℃
Mechanical conditions	The vibration should not exceed the following limits: 2Hz≤f<9Hz, displacement 7.5mm; 9Hz≤f<200Hz, acceleration 20m/s <sup>2</sup> ; 200Hz≤f<500Hz, acceleration 40m/s <sup>2</sup> ;
Storage environment	Requirements

<b>Transportation environment</b>	<b>Requirements</b>	
Storage place	Store in a warehouse with air circulation, no harmful gases, no flammable and explosive substances, and no corrosive substances. Avoid strong mechanical vibration and impact; stay away from strong magnetic fields.	
Ambient temperature	-25℃~+70℃	
Relative humidity	≤95%	
Mechanical conditions	The vibration should not exceed the following limits: 10Hz≤f<57Hz, displacement 0.075mm; 57Hz≤f<150Hz, acceleration 10m/s <sup>2</sup> ;	
<b>Working environment</b>	<b>Requirements</b>	
	<b>Normal operating state</b>	<b>Shut down state</b>
Installation site	<ul style="list-style-type: none"> <li>Usually installed outdoors, at the bottom of the photovoltaic module.</li> <li>Do not install the inverter in areas where flammable and explosive substances are stored.</li> <li>Avoid direct sunlight, rain and snow to extend the life of the inverter. It is recommended to install in a sheltered place. If it can't be satisfied, please build a sunshade.</li> </ul>	
Ambient temperature	-25℃~+60℃ (After exceeding 45℃, the maximum continuous input power and branch current will be derated)	-25℃~+70℃
Relative humidity	≤100%, allow internal condensation	
Altitude	≤4000m, must be derated above 3000m	
Mechanical conditions	Vibration should not exceed the following limits: 10Hz≤f<57Hz, displacement 0.075mm; 57Hz≤f<150Hz, acceleration 10m/s <sup>2</sup> ;	

-- Chapter end --

# 3 System installation

## 3.1 Unpack and inspection

After confirming that the outer packaging is intact, please perform unpacking inspection. Unpack the box and check whether the appearance of the string inverter is good. When opening the packing box, you need to use tools carefully to avoid scratching the string inverter;

The string inverter has been rigorously tested and inspected at the factory, but accidental damage may occur during transportation, so please check the string inverter immediately after receiving the goods. If you find any damage or omissions, please contact Hopewind Technology as soon as possible, our staff will serve you as soon as possible.

## 3.2 Preparation of installation tools

Tool or equipment	Use	Remarks
4#Allen wrench	Disassembly and assembly of the lower door panel of the inverter	
Phillips screwdriver (PH2)	Loosen/tighten the screws of the output terminals and baffles	Bolt spec: M6,M8
Tube terminal crimping pliers	Crimp the communication cable terminal	/
Socket wrench	AC wiring	Bolt spec: M8
MC4 Terminal crimping pliers	Crimp MC4 terminal	The input cable needs to be crimped into the MC4 terminal before it can be connected to the PV + / PV-terminal on the string inverter.
MC4 Removal tool	Remove MC4 terminal	/
Wire stripper	Stripping wire	/
Multimeter	Measure voltage to ensure safety during wiring and installation	/
Safety protective equipment	Labor protection necessary for construction	Insulation shoes, gloves, etc.

## 3.3 Installation environment requirements

- The environmental requirements for the installation of string inverters are shown in "2.10 Ambient Requirements".
- The installation method and position must be suitable for the weight and size of the string inverter, see "2.9 Mechanical Parameters".
- The string inverter should be installed in a well-ventilated environment to ensure good heat dissipation. Protect the inverter from direct sunlight, rain and snow can extend the life of the inverter. It is recommended to choose a sheltered installation site. If it cannot be satisfied, please build a sunshade (optional accessory).
- During the operation of the string-type inverter, the temperature of the chassis and heat sink will be relatively high, please installed the inverter in a location where it will not be accidentally touched.

Note: This chapter takes hopesun 30KTL as an example to introduce the cable connection methods for installation. The interfaces of other models may be a bit different, so please connect cables according to actual situation while referring to this chapter.

### 3.4 Requirements for reserved space

When installing string inverters, proper space must be reserved around the string inverters to facilitate heat dissipation and maintenance.

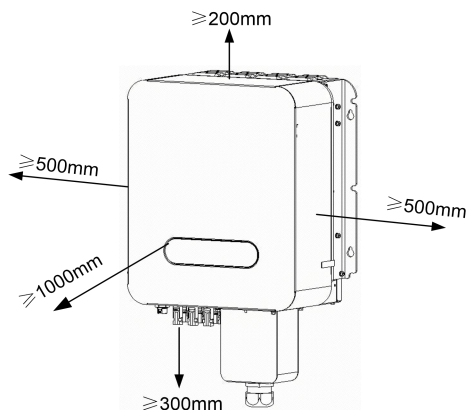

Figure 3-1 Installation space of string inverter

When multiple string devices are installed on the same plane, it is recommended to install in a straight line.

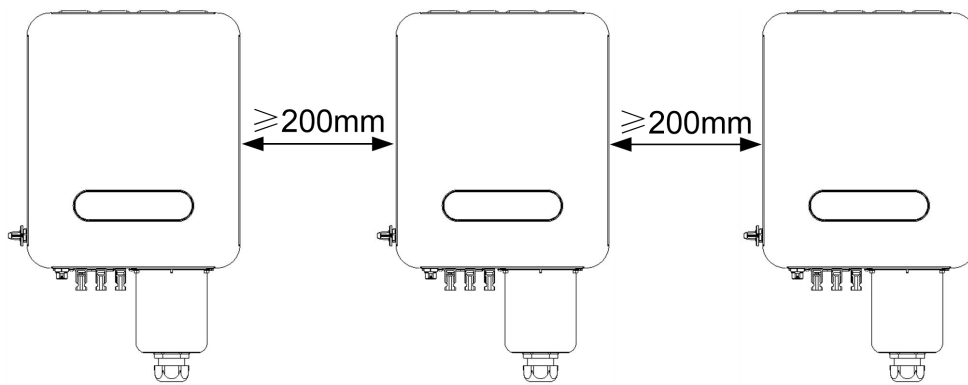

Figure 3-2 Installation space of string inverter

If you need to install it in two rows, it is recommended to install them in the shape of triangle.

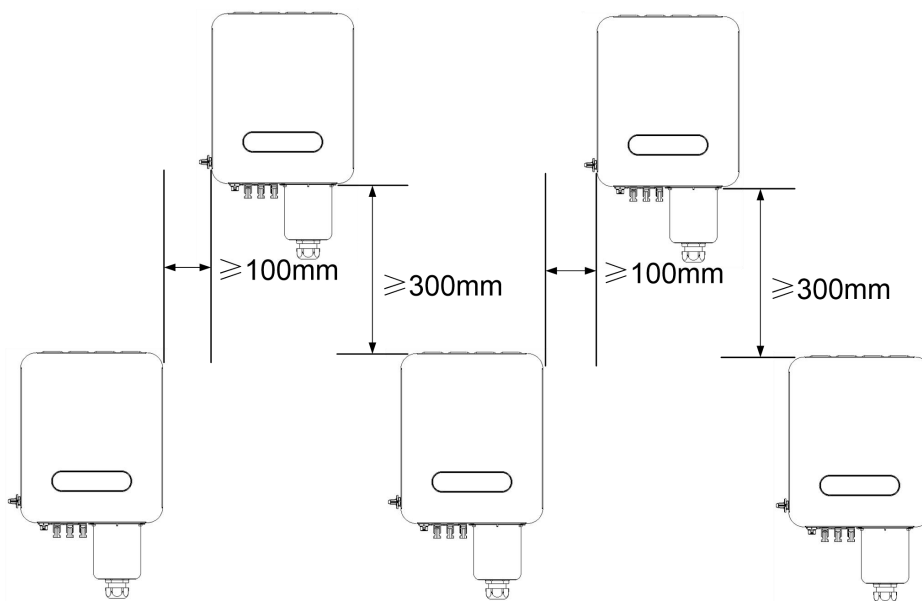

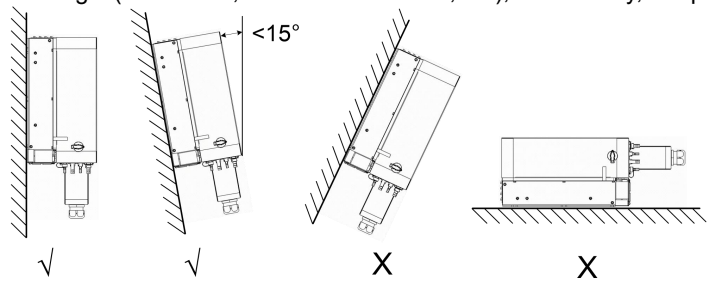

Figure 3-3 Installation space of string inverter

## 3.5 Fixing method

**WARNING**

1. For precautions during inverter installation, please refer to "1 Safety Precautions"; for installation environment requirements, please refer to "3.3 Installation environment requirements".
2. During installation, it must be confirmed that the on-site installation position can bear the total weight of the inverter and accessories to avoid falling during installation or use.
3. It is recommended that four people work together to fix the inverter to avoid mechanical injury. During the installation process, safety measures should be taken to prevent damage.
4. Please install it vertically or tilt it up to 15 ° backward to facilitate heat dissipation. Do not install the inverter at an angle (tilt forward, tilt backward > 15 °, roll), horizontally, or upside down.



5. If direct sunlight cannot be avoided, please add a sunscreen.

### ➤ Installation steps

1. Refer to the fixed hole size of the inverter, use a drill with 100mm diameter to make holes in the wall or bracket. The hole depth in the wall is about 80mm.
2. Unload 4PCS M6 casing reinforced expansion anchor into the wall holes, or use M6 combination bolts to pass it from the back to the front of the bracket. And use flat washers/nuts to fix it in the front side.

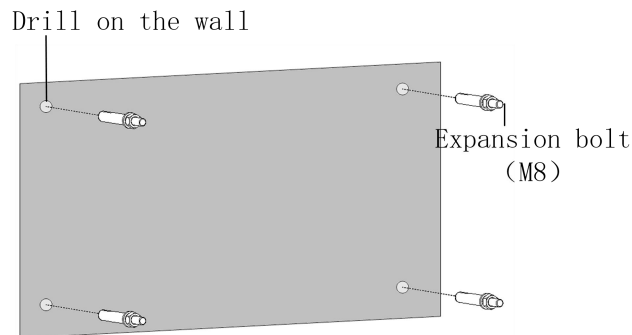

Figure 3-4 Schematic diagram of drilling holes

3. Hang the inverter on the screw of the expansion bolt or combination screw, and use spring washers/flat washers/nuts to fix it.

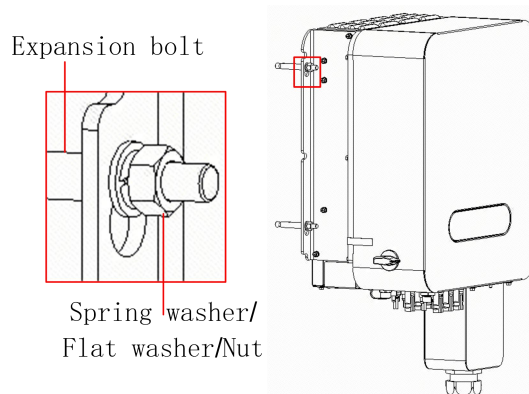

Figure 3-5 Schematic diagram of wall-mounted (hoop) installation

### 3.6 Electrical connection

#### 3.6.1 Cable requirements

The selection of cables should meet the relevant national standards and can meet the load requirements.

- Power cable requirements

Select the cable specifications refer to the electrical data in the product data and the environmental temperature, current, margin and other factors.

- Communication cable requirements

Because the weak communication signal is susceptible to external interference, the communication cable needs to use a cable with a shielding layer, and ground the shielding layer as shown in the following figure. You can also refer to the relevant document "GB 50217-2007 Cable Design Code".

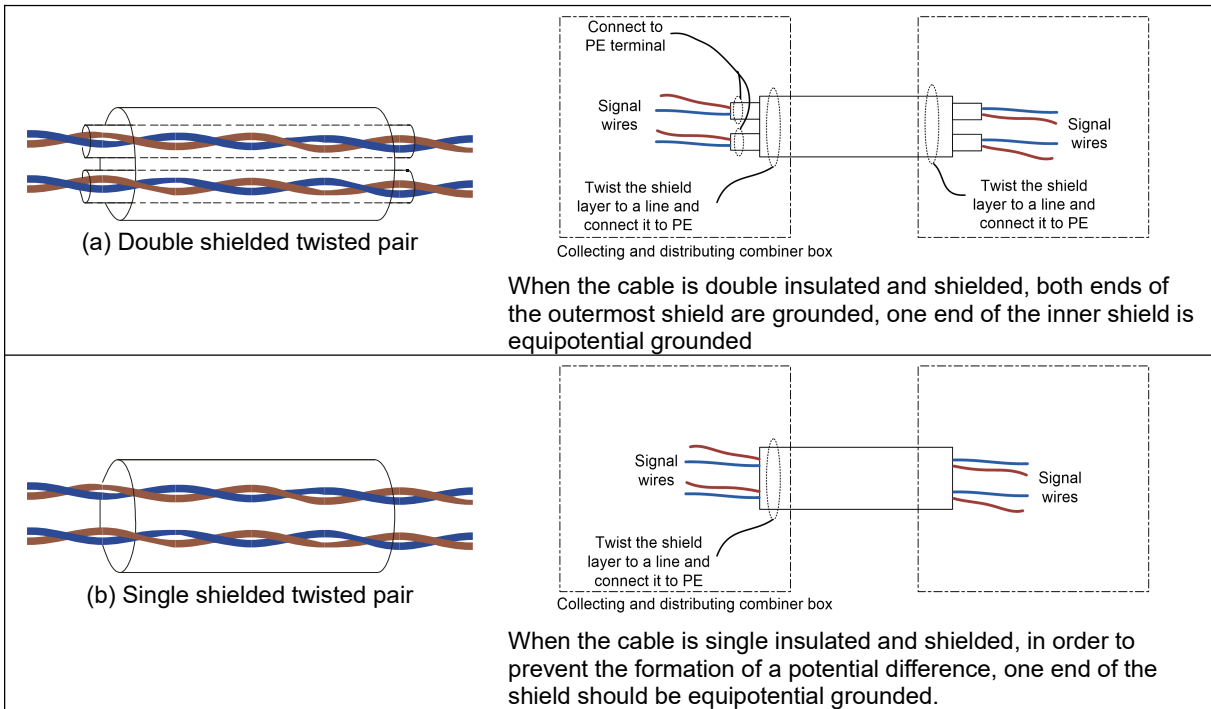

Figure 3-6 Twisted pair with shielding

#### 3.6.2 Recommended cable specifications

Name	Recommended Cable Specifications			Remarks
PV branch input cable	Industry general PV cable, model: PV1-F It is recommended to use a cable with a cross-section of 4.0mm <sup>2</sup> for each PV+ and PV- branch.			/
AC output cable	Model	4 core copper wire (recommended)	4 core aluminum wire (recommended)	AC output Waterproof lock specifications
	8-12kW	10mm <sup>2</sup>	16mm <sup>2</sup>	≤18mm
	15-17kW	16mm <sup>2</sup>	25mm <sup>2</sup>	≤21mm
	20-22kW	25mm <sup>2</sup>	35mm <sup>2</sup>	≤21mm
25-33kW	35mm <sup>2</sup>	50mm <sup>2</sup>	≤32mm	
PE ground cable	It is recommended to use at least one grounded dedicated cable with a cross-sectional area of 16mm <sup>2</sup> .			/

### 3.6.3 Torque requirements

When tightening the cable connection, the tightening torque needs to meet the requirements of the following table.

Table 3-1 List of tightening torques for threaded connections

Thread spec	Performance grade 4.8		Performance grade 8.8		Unit
	Common Connection	High density connection	Common Connection	High density connection	
M3	6	8			kgf.cm
M4	12	14			kgf.cm
M5	25	30			kgf.cm
M6	50	60			kgf.cm
M8			110	150	kgf.cm
M10			300	390	kgf.cm
M12			550	650	kgf.cm
M16			1600	2000	kgf.cm

Note: All bolts with a nominal diameter of 8mm or more in the string inverter of our company are 8.8 Dacromet bolts.

### 3.6.4 Preparation before operation

 <b>DANGER</b>	
<ol style="list-style-type: none"> <li>1. When connecting the cable, it is forbidden to operate in electricity, and observe the relevant requirements in "1 Safety Precautions".</li> <li>2. Before connecting the cable, please complete the following preparations to avoid personal injury.               <ol style="list-style-type: none"> <li>1) Make sure that the "DC SWITCH" of the inverter is in the "OFF" state, otherwise the high voltage of the inverter may cause electric shock.</li> <li>2) Confirm the positive and negative poles of the input cable and mark them well. Make sure that the input cable is disconnected from the PV array (make sure that the cable is not live when crimping the input MC4 terminal).</li> <li>3) Confirm that the open circuit voltage of the PV array does not exceed the specified limit.</li> </ol> </li> <li>3. When connecting the input cable, make sure that the positive and negative poles of the input cable correspond to the positive and negative poles of the PV terminals of the string inverter.</li> </ol>	

### 3.6.5 Connect the ground wire

Connect the inverter to the ground bar through the protective ground wire to achieve the purpose of ground protection. The PE mark is affixed to the PE terminal. The diameter of the ground cable is not less than 16mm<sup>2</sup> and the bolt spec is M6.

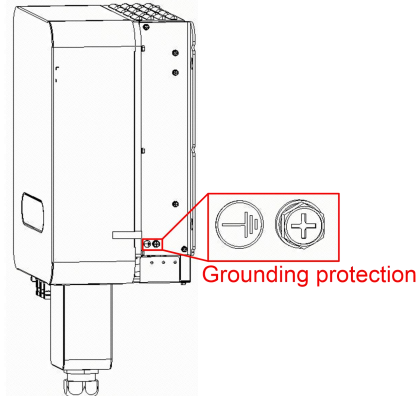

Figure 3-7 PE terminal

For the grounding of multiple string inverters, please use single-point grounding instead of winding the ground wire into a ring, as shown below.

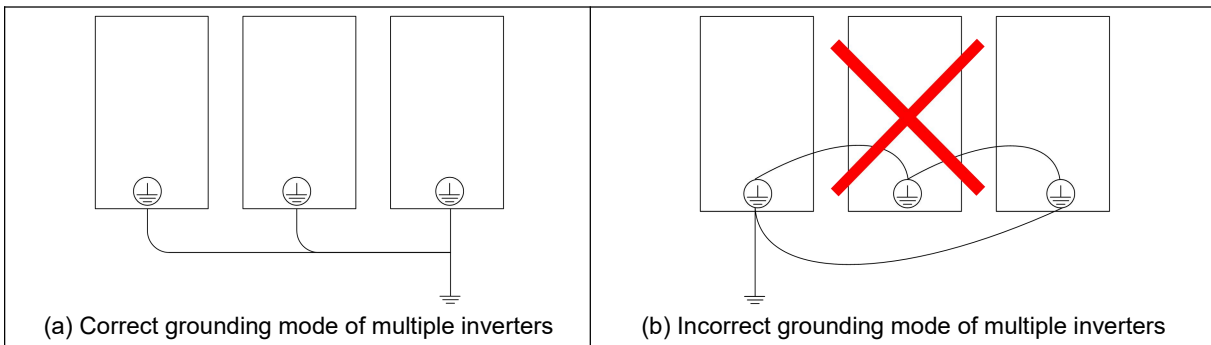

Figure 3-8 Grounding of multiple string inverters

### 3.6.6 Connect the AC output cable

➤ Matters needing attention

- An independent three-phase circuit breaker must be configured outside the AC side of each inverter to ensure that the inverter is reliably disconnected from the power grid. And the circuit breaker specifications should meet the technical requirements.
  - It is forbidden for multiple inverters to share a circuit breaker.
  - It is forbidden to connect the load between the inverter and the circuit breaker.
  - Users need to prepare their own cables. Recommended value of wire cross-sectional area for copper wire is 10mm<sup>2</sup>. The bolt specification is M8.

➤ Operation steps

- (1) Unscrew the locking cap on the “AC OUTPUT” waterproof lock on the bottom of the inverter.
- (2) Pass four cables of 10mm<sup>2</sup> into the locking cap and the “AC OUTPUT” waterproof lock on the bottom of the inverter in sequence, and connect to the AC terminal block in turn on A, B, C, N. Tighten them with a screwdriver, then tighten the waterproof lock, and connect it to the terminal on the inverter. Twist the shielding layer of the AC cable into a bundle and connect it to the PE terminal. Take 30KTL as an example, other models please refer to the actual situation.
- (3) Replace the AC cable shield, and then tighten the waterproof lock.



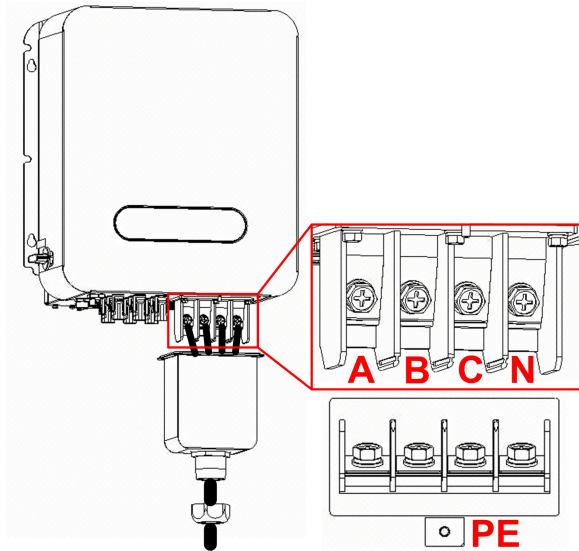

Figure 3-9 Grounding of multiple string inverters

### 3.6.7 Connect the communication cable

- Selection of communication method

The inverter supports anti-backflow interface and RS485 communication.

- Connecting the cables

Connect RS485 cables

- 1) Take out the anti-backflow communication terminal from the accessories. Insert the terminal communication cables which have been crimped and reinforce them with bolts. As for the scenario that the 485 loop grid works, it is necessary to short-circuit the matching resistance of the fourth pin of the inverter at the end and the first pin in the figure below. And that will improve the quality of the communication. There is no need to short-circuit them in other occasions.

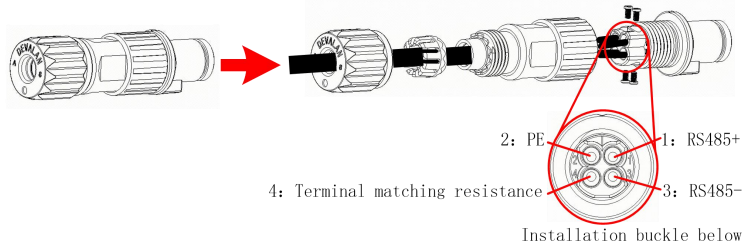

Figure 3-10 Connect cables to the terminal

- 2) Insert the communication terminal into the anti-backflow communication interface after reassemble the communication terminal. Make sure that the connection is sturdy.

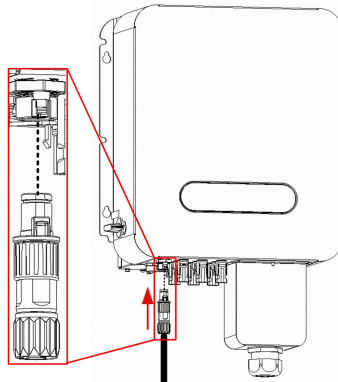

Figure 3-11 Connect the terminal to the inverter

#### GPRS Communication Mode Connection

Connect the GPRS mode in the accessories to the 4-pin interface of the inverter. Make sure the connection is sturdy.

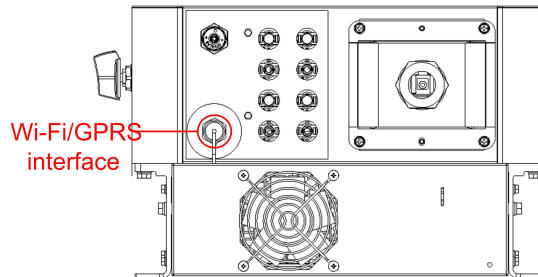



Figure 3-12 Location of the Wi-Fi/GPRS interface

### 3.6.8 Connect DC input cables

-  In order to make full use of the DC input power, the photovoltaic string of the same input MPPT should have the same structure, including the same model, the same number of panels, the same inclination and the same azimuth.



1. Sunlight will produce voltage on the battery panels, which may cause life danger. So connect the DC input line under the condition of light, you need to ensure that the input line is not live (the battery panels can be covered with an opaque cloth before operate).
2. Before connecting the input line, make sure that the DC side voltage is within the safe voltage range (that is, within 60VDC), and the inverter "DC SWITCH" is in the "OFF" state, otherwise the resulting high voltage may cause electric shock.
3. It is forbidden to perform maintenance operations on the DC input line when the inverter is connected to the grid, otherwise it will cause electric shock.
4. If you want to remove the positive and negative connectors, please make sure that "DC SWITCH" has been put into "OFF" state and there is no current output from the PV branch.



Please ensure that the following conditions are met, otherwise it may cause a fire hazard.

- Each serially connected component of the string is of the same specification and model.
- The maximum opening voltage of each PV string cannot be greater than 1100VDC under any circumstances.
- The maximum short-circuit current of each PV string should not exceed 15A under any conditions.
- Ensure that the polarity of the DC input side is connected correctly, that is, the positive electrode of the photovoltaic module is connected to the positive electrode of the DC input terminal of the inverter, and the negative electrode is connected to the negative electrode of the DC input terminal of the inverter.

#### ➤ Precautions for PV string grounding

If the inverter is directly integrated into the power grid and the N cable is connected to the protective ground cable (such as a low-voltage power distribution grid or a grid where the N cable is connected to the ground cable), the positive or negative poles of the photovoltaic string are forbidden being grounded, otherwise the inverter will not be able to work normally.

#### ➤ Steps of crimping MC4 terminal

The input cable needs to be crimped into MC4 terminals in order to connect with the PV+/PV- terminals of the string inverter. Before operation, make sure that "3.6.4 Preparation before operation" is completed.

1. Make sure the positive and negative poles of the input cable have been confirmed and marked.

Note: Please do not judge the positive and negative according to the cable color in this manual. Be sure to refer to the actual measurement.

2. Strip the wire with a wire stripper.

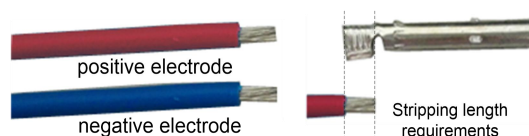

Figure 3-13 Stripping

3. According to the correct polarity, crimp the cable to the corresponding core.

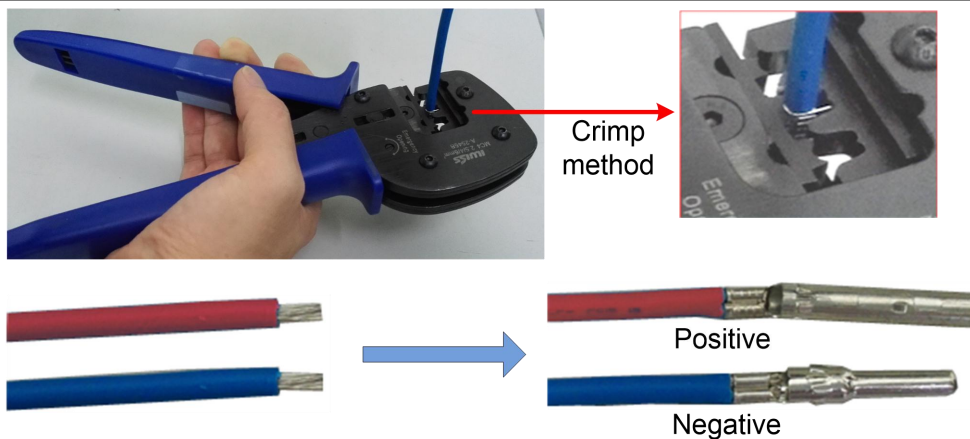

Figure 3-14 Crimp terminals

4. Insert the core into the male and female ends of the MC4 connector with the correct polarity, and tighten the connector back cover.

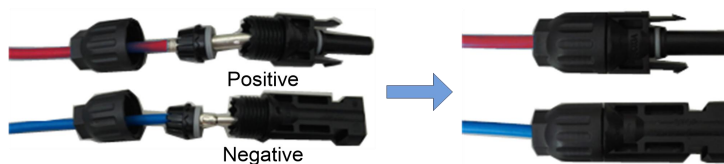

Figure 3-15 Assembly connectors

➤ Insert MC4 terminal

Insert the positive and negative connectors into the positive and negative terminals of the DC input of the inverter until you hear a “click”, indicating that the terminal is stuck in place.

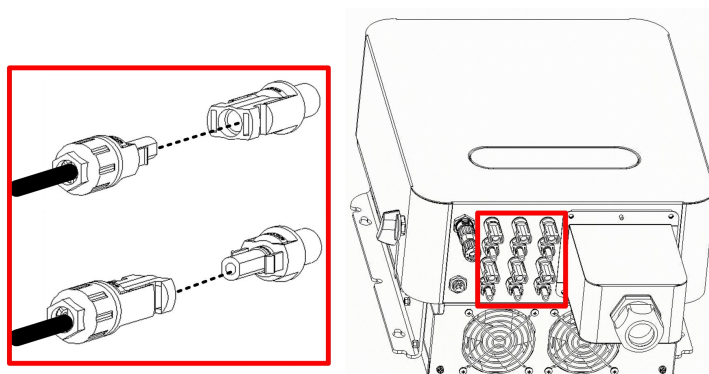
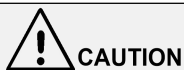

Figure 3-16 Connect DC terminals



After the cable connection of the string inverter is completed, check if there is a gap at the waterproof lock and block the gap by fireproof mud. If there are unconnected input terminals, seal the unconnected input terminals.

-- Chapter end--

# 4 Commissioning Guide

## 4.1 Check before starting



- Before proceeding to the next step of power on, please read "1 Safety Precautions" carefully and do a detailed check according to the table below.
- In order to avoid danger, the multimeter and other instruments must be used to detect the voltage between the metal parts in the inverter with the shell (protective ground) of the inverter.

Once the string inverter is installed, the following items need to be checked carefully before power on.

### **Mechanical inspection**

- Please read "1 Safety Precautions" carefully
- Make sure that the environment of the string inverter is within the normal range.
- Whether foreign objects are left in or on the top of the string inverter cabinet.
- There is enough space around the string inverter to facilitate maintenance and heat dissipation.
- No flammable or explosive items within 2 meters.
- The cable marking is clear and correct.
- Make sure that there is no condensation inside the string inverter. If found, remove it with a heating tool.
- Make sure that all wiring screws are tightened according to torque requirements.
- Make sure there are no gaps between the input terminal and the waterproof lock.

### **Electrical inspection**

- Make sure the wiring of the string inverter is reliable and the polarity is correct.
- The power cables and signal lines used are in compliance with electrical safety regulations.
- The signal wire and power wire should use the matching terminal correctly.
- Isolation areas and warning signs have been set around the string inverters to prevent others from misoperation or approaching.

## 4.2 Power on the system

After ensuring that the electrical connection is completed normally, you can perform the power-on operation and turn on the inverter.

**Step 1:** Put the "DC SWITCH" of the inverter into the "ON" state.

**Step 2:** Close the AC circuit breaker between the inverter and the power grid.

After performing the above steps, if there is no fault in the system and the start-up conditions are met, the inverter will start up automatically.

## 4.3 Power off the system

➤ Matters needing attention

- After the inverter is powered off, there will be residual power and residual heat in the chassis, which may cause electric shock or burns. Be sure to operate the inverter after the inverter system has been powered off for 5 minutes.
- When powering off the system, be sure to follow the operation instruction sequence and safety regulations in this chapter.

**Step 1:** Use the data collector or near-end APP software to issue a shutdown command to shut down the inverter.

**Step 2:** Open the circuit breaker between the inverter and the power grid.

**Step 3:** Put the "DC SWITCH" of the inverter into the "OFF" state.

-- Chapter end --

# 5 Maintenance and troubleshooting

## 5.1 Maintenance items and cycle



1. Before maintenance, please read "1 Safety Precautions" carefully, and use multimeter and other instruments to detect the voltage between the metal parts that may be contacted with the ground to avoid electric shock.
2. During maintenance, please pay attention to the warning label on the inverter to avoid personal injury caused by high voltage.
3. During maintenance, make sure the "DC SWITCH" is in the "OFF" state, and at the same time make sure that the circuit breaker between the inverter and the grid is in open.
4. After maintenance is completed, put the "DC SWITCH" of the inverter into the "ON" state and close the circuit breaker between the inverter and the power grid.

The string inverter needs regular maintenance. The common maintenance items and cycles are shown in the table below.

Table 5-1 Maintenance items and cycles of string inverter

Parts	Item	Inspection matters	Treatment measures	Inspection cycle
Overall inspection	Exterior	Observe whether the appearance of the inverter is damaged or deformed.	Please replace it in time if the inverter is damaged or deformed seriously.	Once every six months to one year
	System cleaning	Whether there are foreign objects and dust on the surface of the inverter.	Remove foreign objects, clean dust.	
		Whether the heat sink is blocked or dirty.	Remove blocker, clean dust.	
System running	Operating status	Whether the inverter makes any abnormal noise during operation.	Please replace it in time if the noise is loud.	Once every six months to one year
	Operating parameters	Check whether each parameter is set correctly when the inverter is operating.	Troubleshoot exception settings.	
Connecting parts	Detached or loose connection	Check if the cable connection is detached or loose.	Tighten the connection according to regulations.	Half a year after the first commissioning, then once every half a year to once a year
	Damage	Check whether the cable is damaged, and focus on checking whether the surface of the cable that contacts the metal surface has signs of cuts.	Please replace it in time if the cable damaged seriously.	
	Terminals	Check whether the waterproof covers of unused terminals are locked	Seal the unused terminals.	

 Note: Before wiping the heat sink, shut down the inverter normally, then disconnect the circuit breaker between the inverter and the power grid, and then put the "DC SWITCH" of the inverter into the "OFF" state. After power off, wait at least 5 minutes before wiping the heat sink to avoid accidents.

## 5.2 Troubleshooting

### ➤ Boost side

Fault word	ID	Fault/alarm name	Cause of failure/alarm	Troubleshooting
Fault word 1	0	Auxiliary power supply overvoltage	12V below or above auxiliary power supply is too high	1. Reset and check if the converter works normally. 2. If it appears frequently, please contact Hopewind technical staff.
	1	Auxiliary power supply under voltage	12V below or above auxiliary power supply is too low	1. Reset and check if the converter works normally. 2. If it appears frequently, please contact Hopewind technical staff.
	2	Output hardware overvoltage	The output voltage exceeds the protection point set by the hardware.	1. Reset and check if the converter works normally. 2. If it appears frequently, please contact Hopewind technical staff.
	3	Hardware overcurrent (level 2)	Unit inductor current is too large.	1. Reset and check if the converter works normally. 2. If it appears frequently, please contact Hopewind technical staff.
	4	Unit 1 hardware overcurrent	Unit 1 overcurrent and reached the hardware wave-by-wave current limit time.	1. Reset and check if the converter works normally. 2. If it appears frequently, please contact Hopewind technical staff.
	5	Unit 2 hardware overcurrent	Unit 2 overcurrent and reached the hardware wave-by-wave current limit time.	1. Reset and check if the converter works normally. 2. If it appears frequently, please contact Hopewind technical staff.
	6	Unit 3 hardware overcurrent	Unit 3 overcurrent and reached the hardware wave-by-wave current limit time.	1. Reset and check if the converter works normally. 2. If it appears frequently, please contact Hopewind technical staff.
	7	Unit 4 hardware overcurrent	Unit 4 overcurrent and reached the hardware wave-by-wave current limit time.	1. Reset and check if the converter works normally. 2. If it appears frequently, please contact Hopewind technical staff.
Fault word 2	2	EEPROM parameters back to default value	EEPROM read and write errors.	Reset or power-off processing.
	3	History failure storage failure	History failure storage failure.	Reset or power-off processing.
	12	Input polarity reversed	Reverse input polarity.	Check if the connection is reversed.
	13	Positive bus bar insulation fault	Abnormal insulation resistance of positive bus bar to ground.	Check the positive bus for ground faults.
	14	Negative bus bar insulation fault	Abnormal insulation resistance of negative bus bar to ground.	Check the negative bus for ground faults.
Alarm word 1	0	SPD alarm	Feedback SPD failure of in wrong state.	1. Reset and check if the converter works normally. 2. If it appears frequently, please contact Hopewind technical staff.
	6	Open circuit warning on boost side	Boost unit open circuited.	Please contact Hopewind technical staff.
	7	Short circuit warning	Boost unit short circuited.	Please contact Hopewind technical staff.



Fault word	ID	Fault/alarm name	Cause of failure/alarm	Troubleshooting
		on boost side		
	8	Abnormal PV string alarm	Abnormal PV string.	<ol style="list-style-type: none"> <li>1. Detect whether the PV string configuration is abnormal.</li> <li>2. Check whether the battery panel access is abnormal.</li> <li>3. Check whether the battery string current sampling is abnormal.</li> </ol>
	9	Positive bus-to-ground insulation alarm	Abnormal insulation resistance of the positive bus to the ground	Find the cause of impedance abnormality.
	10	Negative bus-to-ground insulation alarm	Abnormal insulation resistance of the negative bus to the ground	Find the cause of impedance abnormality.

➤ Inverter side

Fault word	ID	Fault/alarm name	Cause of failure/alarm	Troubleshooting
System fault status word	0	RAM self-test failed	Detect RAM chip read and write errors.	<ol style="list-style-type: none"> <li>1. Reset and check if the converter works normally.</li> <li>2. If it appears frequently, please contact Hopewind technical staff.</li> </ol>
	1	EEPROM parameters back to default value	Add EEPROM parameter list and re-upgrade the code, the default value after initialization is different from the default value in EEPROM.	<ol style="list-style-type: none"> <li>1. Reset and check if the converter works normally.</li> <li>2. If it appears frequently, please contact Hopewind technical staff.</li> </ol>
	2	EEPROM read and write fault		<ol style="list-style-type: none"> <li>1. Reset and check if the converter works normally.</li> <li>2. If it appears frequently, please contact Hopewind technical staff.</li> </ol>
	3	FPGA version does not match	FPGA and DSP versions do not match.	<ol style="list-style-type: none"> <li>1. Reset and check if the converter works normally.</li> <li>2. If it appears frequently, please contact Hopewind technical staff.</li> </ol>
	4	History failure storage failure	History failure storage failure.	<ol style="list-style-type: none"> <li>1. Reset and check if the converter works normally.</li> <li>2. If it appears frequently, please contact Hopewind technical staff.</li> </ol>
	5	Internal communication fault	Internal communication failed.	<ol style="list-style-type: none"> <li>1. Reset and check if the converter works normally.</li> <li>2. If it appears frequently, please contact Hopewind technical staff.</li> </ol>
Hardware fault status word	0	Hardware overcurrent (level 2)	Peak inductor current exceeds hardware protection threshold.	<ol style="list-style-type: none"> <li>1. Reset and check if the converter works normally.</li> <li>2. If it appears frequently, please contact Hopewind technical staff.</li> </ol>
	3	Phase A hardware overcurrent	Phase A inductor current triggers wave-by-wave current limit protection.	<ol style="list-style-type: none"> <li>1. Reset and check if the converter works normally.</li> <li>2. If it appears frequently, please contact Hopewind technical staff.</li> </ol>
	4	Phase B hardware overcurrent	Phase B inductor current triggers wave-by-wave current limit protection.	<ol style="list-style-type: none"> <li>1. Reset and check if the converter works normally.</li> <li>2. If it appears frequently, please contact Hopewind technical staff.</li> </ol>

Fault word	ID	Fault/alarm name	Cause of failure/alarm	Troubleshooting
	5	Phase C hardware overcurrent	Phase C inductor current triggers wave-by-wave current limiting protection.	1. Reset and check if the converter works normally. 2. If it appears frequently, please contact Hopewind technical staff.
	6	Busbar hardware overvoltage	Bus voltage exceeds hardware overvoltage threshold.	1. Reset and check if the converter works normally. 2. If it appears frequently, please contact Hopewind technical staff.
	7	Busbar midpoint overvoltage	Bus midpoint voltage exceeds hardware overvoltage threshold.	1. Reset and check if the converter works normally. 2. If it appears frequently, please contact Hopewind technical staff.
Grid fault status word	0	Grid AB line overvoltage	The voltage of the AB line of the power grid exceeds the overvoltage point set by the system.	1. Confirm whether the inverter's grid voltage sampling is normal and whether there is a fault such as a box transformer tripped on the AC side at the fault time. 2. Confirm whether the inverter is in HVRT.
	1	Grid BC line overvoltage	The voltage of the BC line of the power grid exceeds the overvoltage point set by the system.	1. Confirm whether the inverter's grid voltage sampling is normal and whether there is a fault such as a box transformer tripped on the AC side at the fault time. 2. Confirm whether the inverter is in HVRT.
	2	Grid CA line overvoltage	The voltage of the CA line of the power grid exceeds the overvoltage point set by the system.	1. Confirm whether the inverter's grid voltage sampling is normal and whether there is a fault such as a box transformer tripped on the AC side at the fault time. 2. Confirm whether the inverter is in HVRT.
	3	Grid AB line undervoltage	The voltage of the AB line of the power grid lower than the undervoltage point set by the system.	Confirm whether the phase loss of the inverter occurs and whether the box transformer contacts are suitable, etc.
	4	Grid BC line undervoltage	The voltage of the BC line of the power grid lower than the undervoltage point set by the system	Confirm whether the phase loss of the inverter occurs and whether the box transformer contacts are suitable, etc.
	5	Grid CA line undervoltage	The voltage of the CA line of the power grid lower than the undervoltage point set by the system.	Confirm whether the phase loss of the inverter occurs and whether the box transformer contacts are suitable, etc.
	6	Abnormal grid	The grid frequency or voltage exceed the system setting range.	1. Confirm whether the connected grid is the nominal grid of the inverter. 2. Confirm whether the power grid is connected.
	7	Grid voltage unbalance exceeded	The grid voltage unbalance exceeds the system threshold.	Confirm whether the power grid is abnormal.
	8	Grid over-frequency	The grid frequency exceeds the over-frequency set by the system.	1. Confirm whether there is a fault such as box transformer tripping on the AC side of the inverter through fault recording and event recording. 2. Confirm whether the frequency range and time setting are reasonable.

Fault word	ID	Fault/alarm name	Cause of failure/alarm	Troubleshooting
	9	Grid under-frequency	The grid frequency is lower than the under-frequency set by the system.	1. Confirm whether there is a fault such as box transformer tripping on the AC side of the inverter through fault recording and event recording. 2. Confirm whether the frequency range and time setting are reasonable.
	11	Island effect protection	Power grid voltage loss.	Detect the cause of grid voltage loss, such as box transformer tripping, etc.
	13	Abnormal grid voltage	Sudden change of grid voltage.	Confirm whether the power grid is normal.
	14	LVRT protection	The grid voltage exceeds the LVRT protection threshold.	Confirm whether the power grid is normal.
	15	HVRT protection	The grid voltage exceeds the HVRT protection threshold.	Confirm whether the power grid is normal.
Invert fault status word	0	Module phase A software overcurrent	The effective value of the inductor current exceeds the protection threshold.	1. Reset and check if the converter works normally. 2. If it appears frequently, please contact Hopewind technical staff.
	1	Module phase B software overcurrent	The effective value of the inductor current exceeds the protection threshold.	1. Reset and check if the converter works normally. 2. If it appears frequently, please contact Hopewind technical staff.
	2	Module phase C software overcurrent	The effective value of the inductor current exceeds the protection threshold.	1. Reset and check if the converter works normally. 2. If it appears frequently, please contact Hopewind technical staff.
	3	Module current imbalance	Three-phase current unbalance exceeds threshold.	Confirm whether the power grid is normal.
	5	Module temperature is too high.	The temperature of the radiator is higher than the protection threshold.	Confirm whether the outer fan is normal.
	6	The internal temperature is too high.	The ambient temperature is higher than the protection temperature.	Confirm whether the outer fan is normal.
	9	Abnormal residual current	Residual current overlimit.	1. If it happens by accident, it may be caused by accidental abnormality of the external line, and the work will be resumed after the fault is cleared without manual intervention. 2. If it appears frequently or cannot be recovered for a long time, please check whether the impedance of the PV string to the ground is too low.
Bus fault word status	1	Bus short circuit	Bus voltage sag overrun.	1. Reset and check if the converter works normally. 2. If it appears frequently, please contact Hopewind technical staff.
	5	Bus overvoltage	Bus voltage exceeds set threshold.	1. Reset and check if the converter works normally. 2. If it appears frequently, please contact Hopewind technical staff.
	6	Bus undervoltage	Bus voltage is lower than the set threshold.	1. Reset and check if the converter works normally. 2. If it appears frequently, please contact Hopewind technical staff.

User Manual of String Inverter

<b>Fault word</b>	<b>ID</b>	<b>Fault/alarm name</b>	<b>Cause of failure/alarm</b>	<b>Troubleshooting</b>
	7	Unbalanced bus voltage	Positive and negative bus voltage unbalance exceeds the set threshold.	1. Reset and check if the converter works normally. 2. If it appears frequently, please contact Hopewind technical staff.
	8	High DC input voltage	DC input voltage exceeds set threshold.	1. Reset and check if the converter works normally. 2. If it appears frequently, please contact Hopewind technical staff.
	9	Low DC input voltage	DC input voltage is lower than the set threshold.	Check if the switch is open.
Other	0	Grid-connected relay fault	Relay status is wrong.	1. Reset and check if the converter works normally. 2. If it appears frequently, please contact Hopewind technical staff.
	3	SPD alarm on the AC side	Detect the SPD feedback status error on the AC side.	1. Reset and check if the converter works normally. 2. If it appears frequently, please contact Hopewind technical staff.
	4	Internal fan fault	Fan failure or abnormal feedback signal	1. Reset and check if the converter works normally. 2. If it appears frequently, please contact Hopewind technical staff.

-- Chapter end --

# 6 Inverter handling instructions

---

## 6.1 Disassembly of the inverter

Before operation, please make sure that the circuit breaker between the inverter and the power grid has been opened and "DC SWITCH" is set to "OFF" state.

- 1) Disconnect all electrical connections of the inverter, including AC output lines, communication lines, DC input lines, and protective ground.
- 2) Remove the inverter from the back panel.

## 6.2 Replace the inverter

After disassembling the old inverter, if you need to replace the new inverter, just follow the operation sequence in chapters 3 and 4.

## 6.3 Package the inverter

- If you still keep the original packaging of the inverter, put it in the original packaging and secure the packaging with tape.
- If you can't find the original packaging, please use a hard carton suitable for the weight and size of the inverter to secure it.

## 6.4 Scrapped the inverter

- When the service life of the inverter expires or after fault replacement, dispose the inverter in accordance with the relevant laws on the disposal of electrical waste in the place of installation or hand it over to Hopewind Technology customer service personnel.

-- Chapter end --

## ➤ Quality assurance

The product that fails during the warranty period will be repaired or replaced by a new product for free.

Due to the following circumstances, the company has the right not to guarantee quality:

- When the user arbitrarily decomposes the product or does not properly maintain the problems arising;
- The whole machine and components have exceeded the free warranty period;
- Beyond the scope of operation and use specified in relevant international standards;
- Problems arising from incorrect installation and operation as described in the manual;
- Product damage caused by abnormal natural environment;
- Machine damage caused by the use of non-standard or non-our company components or software;
- The string inverter is damaged due to damage to external equipment;
- Any accidental damage caused by the user's own modification or repair of this product.

For product failures caused by the above reasons, when the customer requests maintenance services, the company's service organization can provide paid maintenance services as determined by our company. If you need to repair or modify this product, please contact our company in advance.

## ➤ Contact information

Shenzhen Hopewind Technology Co., Ltd.

Address: Guanlong No. 2 Industrial Park, Xili, Nanshan District, Shenzhen, PR.China

Website: [en.hopewind.com](http://en.hopewind.com)

Email: [Globalsupport@hopewind.com](mailto:Globalsupport@hopewind.com)

Tel: +86 189 4874 2347

Fax: +86-(0)755-2651 8311



Address: Building 11, Guanlong No. 2 Industrial Park, Xili, Nanshan District, Shenzhen, PR.China

Postcode: 518055

Customer Service Hotline: 400-8828-705

Tel: + 86- (0) 755-86026786  
Web Site: [www.hopewind.com](http://www.hopewind.com)

Copyright © 2021 Hopewind All Rights Reserved.